

### Differential Bypass Valve

The Taco Differential Bypass Valve provides an accurate and dependable means of controlling excess flow in zone valve systems. As zone valves close, instead of forcing more water through the remaining open zones, the Differential Bypass Valve automatically reroutes the excess flow through the bypass valve. This prevents velocity noise while maintaining the designed heat transfer of each zone, enhancing overall system performance.



HYDRONIC COMPONENTS & SYSTEMS

Do it once.  
Do it right.® **Taco**®

# Submission Data Information Differential Bypass Valve

## Application

Differential Bypass Valves are used to control excess flow velocities that can be created when there is a reduction in the demand for heat. This reduced heat demand would typically occur as zone thermostats are satisfied and their corresponding zone valves close, causing the system pump to try and force more water through the remaining zones. By installing a Taco Differential Bypass Valve between the discharge of the system pump and somewhere before the inlet of the pump, usually on the system return, an automatically regulated flow path is created. This regulated flow path will prevent unacceptable velocities from being pumped through the zones that remain open during reduced demand periods. Differential Bypass Valves should also be used to prevent dead heading of the circulator in systems where parallel piped heat emitters are controlled by thermostatic radiator valves.

## Operation

The Bypass Valve uses an adjustable spring loaded seat that opens and closes to allow flow through the valve. This opening and closing is based on the system pressure applied to the valve seat and the set point of the valve.

## Materials of Construction

Body:	Brass
Indicator:	Brass
Union Nut:	Brass
Internals:	Stainless Steel and Engineered Plastics
O-Ring:	EPDM
Gasket:	Non Asbestos

## Differential Bypass Valve Ratings

Maximum Pressure:	200 PSI
Maximum Temperature:	200°F
Adjustment Range:	0 to 7.5 PSI

## Flow Characteristics By Setting

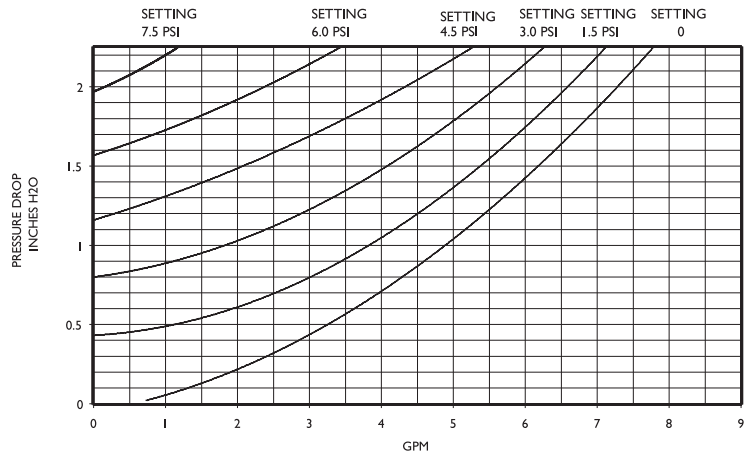

## Dimensions

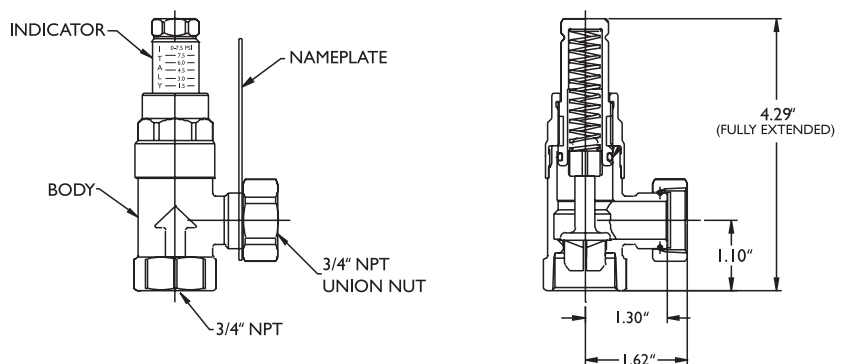

## Typical Installation

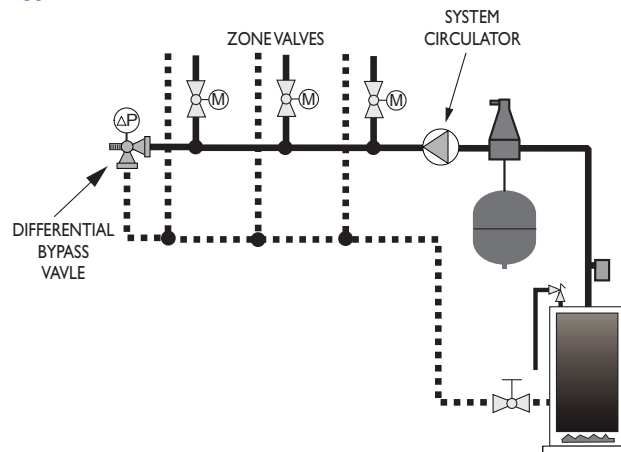

HYDRONIC COMPONENTS & SYSTEMS

