

WARRANTY/RETURNED GOODS

FOR DEFECTIVE HEAT EXCHANGERS (HEAT EXCHANGER WARRANTY CLAIM FORM)

Request for warranty consideration must include:

Beacon-Morris Part Number

Unit model number

Serial Number

Description of failure

A completed Heat Exchanger Warranty Claim Form must be submitted including all the above information. The request will be reviewed by the Technical Service Department and if the claim is approved we will either issue a credit for the replacement heat exchanger ordered in advance or send a replacement. If the claim is denied, a complete explanation will be provided. Occasionally it may be necessary for a heat exchanger to be inspected in the field or at the factory so the part must be held until the claim is accepted.

**PLEASE REMEMBER THAT FREIGHT CHARGES ARE NOT
COVERED UNDER OUR WARRANTY**



WARRANTY CLAIM

Name			Date		
Company			Sterling Order #		
Address			Sterling Invoice#		
City			P.O.#		
State		Zip	Customer #		
Telephone			Rep Name		
Fax					
Unit Model #			Contractor		
Serial #			Telephone #		
Requesting Credit			Application		
Requesting Replacement			Job Name		

*****PARTS MUST BE HELD UNTIL CLAIM IS ACCEPTED*****

Description of Failure	
------------------------	--

INDICATE LOCATION OF DEFECT ON DRAWING BELOW

FRONT

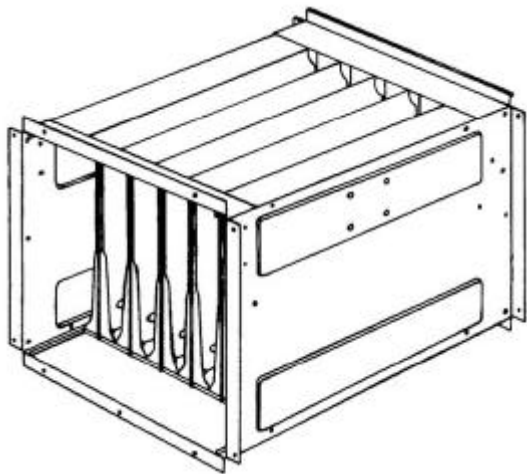

BACK

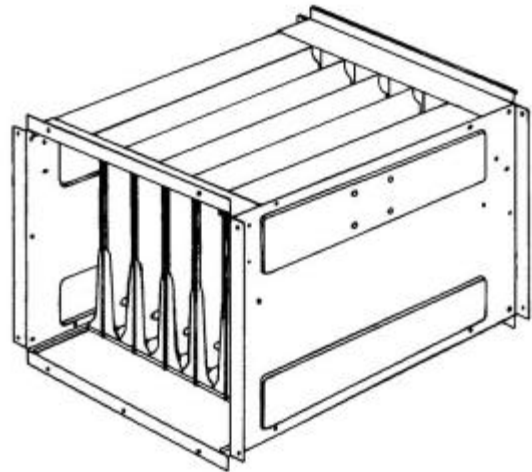

Claim Denied

Claim Approved

Reason

Credit Amount

Replacement
Order Number

FAX TO 413-572-3764